

London Garden Table & Bench Set

Fitting Instructions

Kennings

Component List

Table

6 x Table Top 4x2 1580mm	(A)
1x Table Top Under-Support 4x2 580mm	(B)
2 x Table Top Corner Supports 2x2 580mm (Angle Cut)	(C)
12 x Table Leg 4x2 800mm (Notched)	(D)
2 x Table Leg Footing Blocks 2x2 580mm	(E)

Bench 1

3 x Bench Top 4x2 1470mm	(F)
1 x Bench Top Under-Support 4x2 290mm	(G)
2 x Bench Top Corner Supports 2x2 290mm (Angle Cut)	(H)
6 x Bench Leg 4x2 500mm (Notched)	(I)
2 x Bench Leg Footing Blocks 2x2 290mm	(J)

Bench 2

3 x Bench Top 4x2 1470mm	(F)
1 x Bench Top Under-Support 4x2 290mm	(G)
2 x Bench Top Corner Supports 2x2 290mm (Angle Cut)	(H)
6 x Bench Leg 4x2 500mm (Notched)	(I)
2 x Bench Leg Footing Blocks 2x2 290mm	(J)

Fixings

Box of 200 x 75mm Green Screws	(K)
--------------------------------	-----

Tools Required:

Drill driver

Pencil

Tape measure

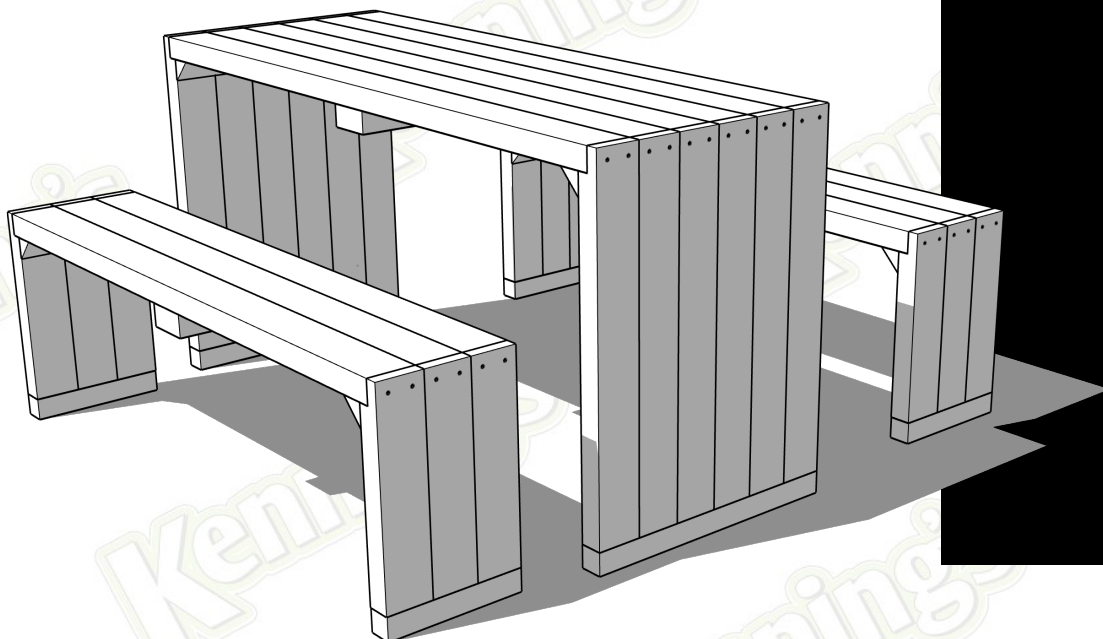

All images are for illustration only. Please see individual item listings for actual item specifications.

Page 1 of 6

London Garden Table & Bench Set

Fitting Instructions

Kennings

Section 1 — Building the table

Step 1

Take one of the Table Leg Footing Blocks 580mm (E) and fix six of the Table Legs 800mm (D) side by side along the block. Use 2 x 75mm Green Screws (K) per attachment going in from the underside of the footing block (E).

Repeat the above for the opposite side.

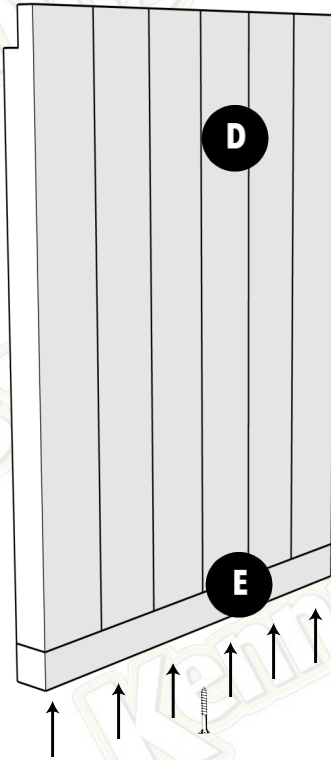

Step 2

Rest the 6 x Table Top 1580mm (A) in to the notches on top of the two table legs made in Step 1, and secure from the side using 2 x 75mm Green Screws (K) per attachment at both ends.

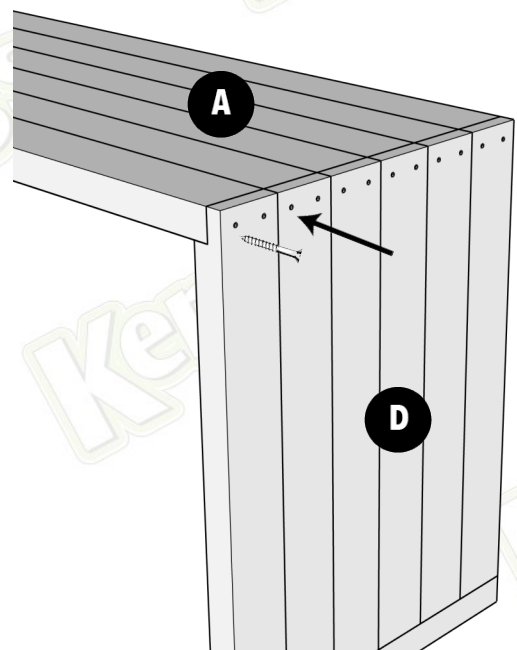

All images are for illustration only. Please see individual item listings for actual item specifications.

Page 2 of 6

Section 1 — Building the table

Step 3

Working on the underneath of the top of the table, centralise the Under Support 580mm (B) and fix to the table using two 75mm Green Screws (K) per Table Top 4x2 1580mm (A). Drive underneath and into the table top. Screw Corner Supports 580mm (C) in to each corner, using six equally spaced 75mm Green Screws (K) per attachment. One screw in to each leg piece.

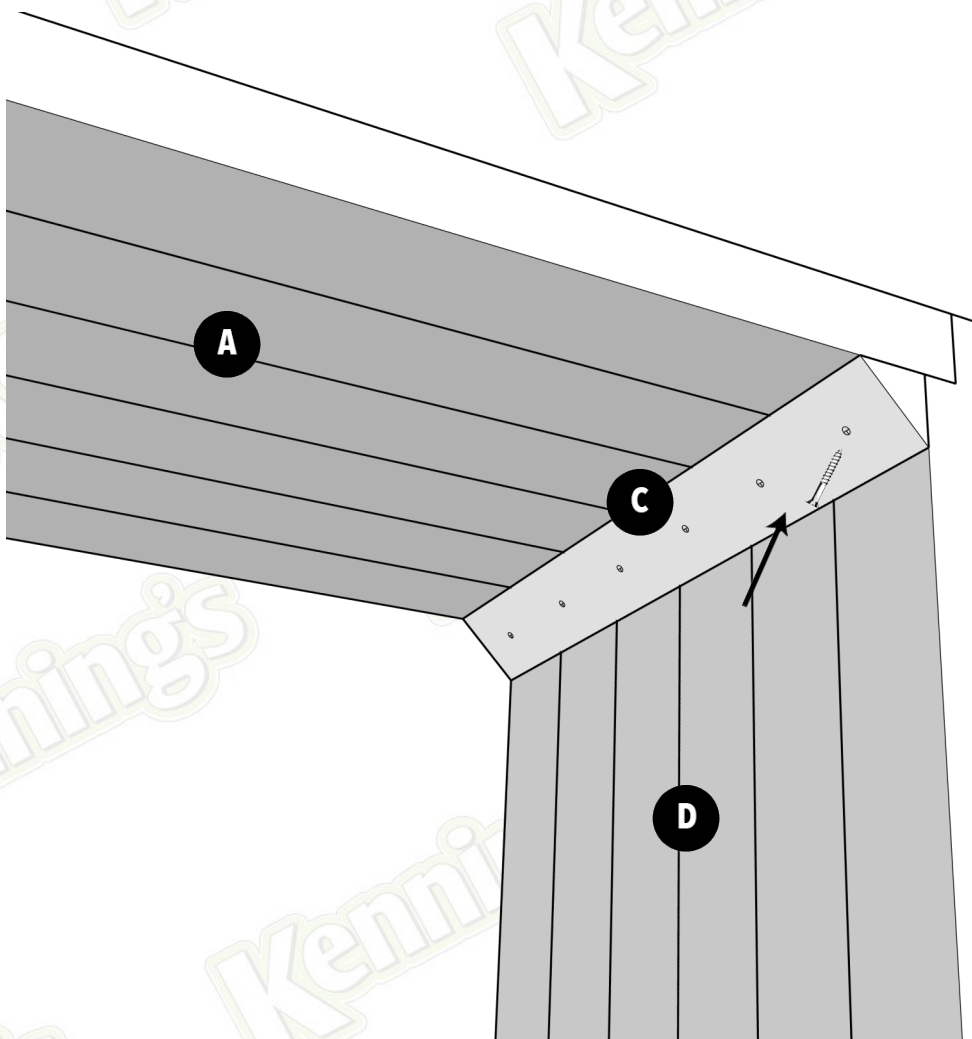
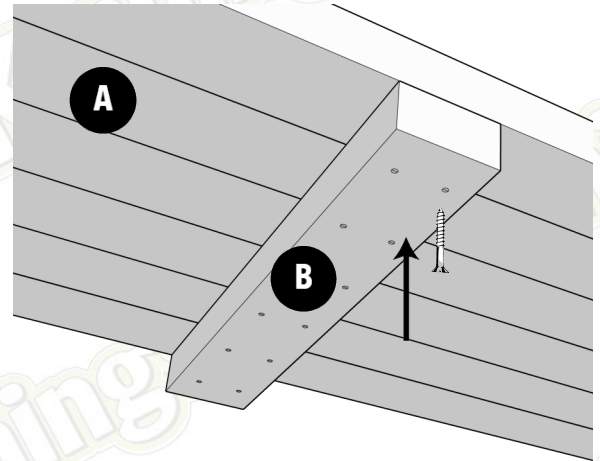

All images are for illustration only. Please see individual item listings for actual item specifications.

London Garden Table & Bench Set

Fitting Instructions

Kennings's

Section 2 — Building the benches

Step 1

Take one of the Bench Leg Footing Blocks 290mm (**J**) and fix the three Bench Legs 500mm (**I**) side by side along the block. Use 2 x 75mm Green Screws (**K**) per attachment, going in through the underside of the footing block.

Repeat the above for the opposite side.

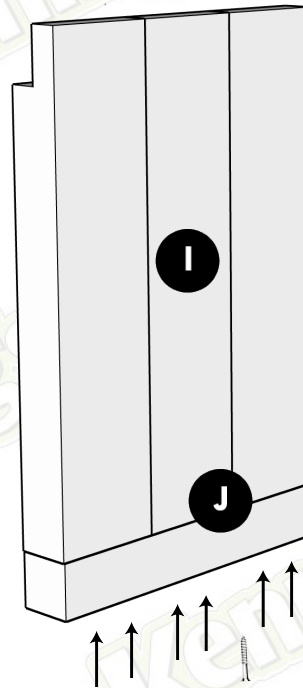

Step 2

Rest the 6 x Bench Top 1470mm (**F**) in to the notches on top of the two Bench Legs made in Step 1. Secure by using 2 x 75mm Green Screws per attachment (**K**) at both ends.

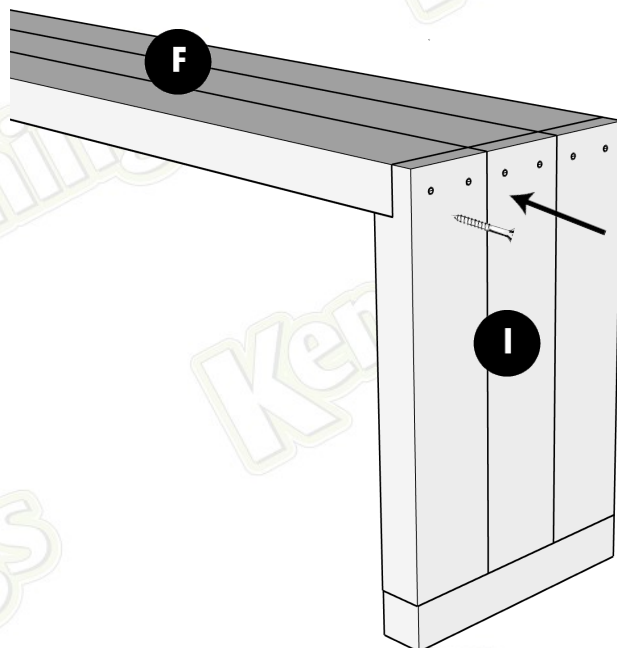

All images are for illustration only. Please see individual item listings for actual item specifications.

Page 4 of 6

Section 2 — Building the benches

Step 3

Working on the underneath of the top of the bench, centralise the Under Support 290mm (**G**) and fix to the bench using 2 x 75mm Green Screws (**K**) per Bench Top 4x2 1470mm (**F**). Then, screw Corner Supports 290mm (**H**) in to each corner. Use 3 x 75mm Green Screws (**K**), one in to each leg piece.

Repeat steps 1-3 to make the second bench.

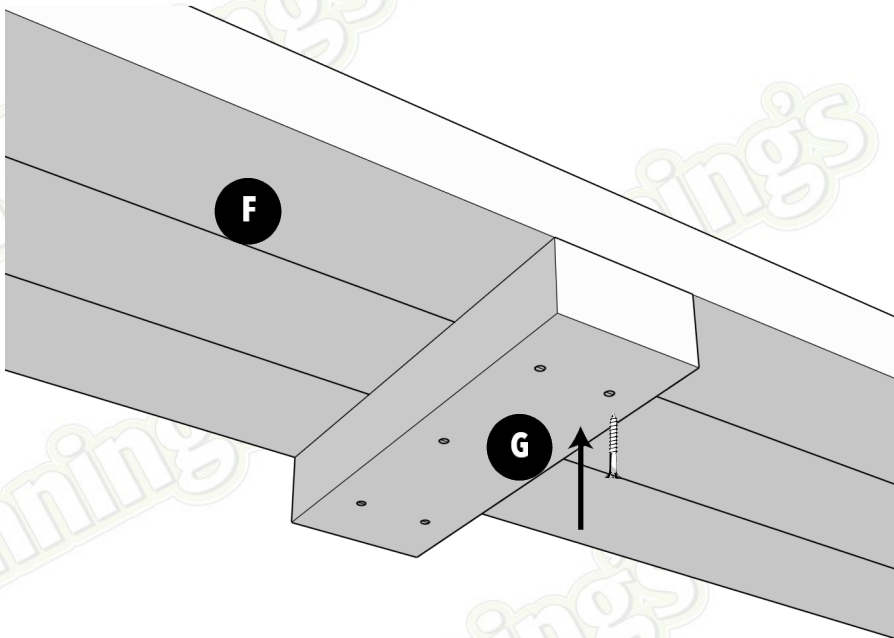
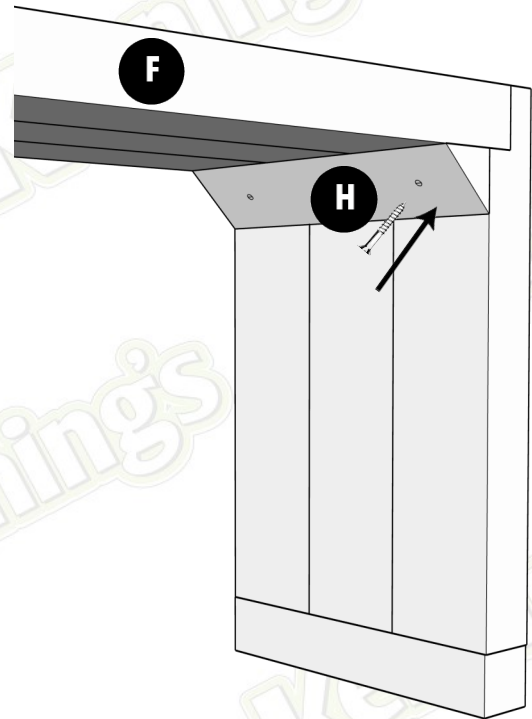

London Garden Table & Bench Set Fitting Instructions

Kennings

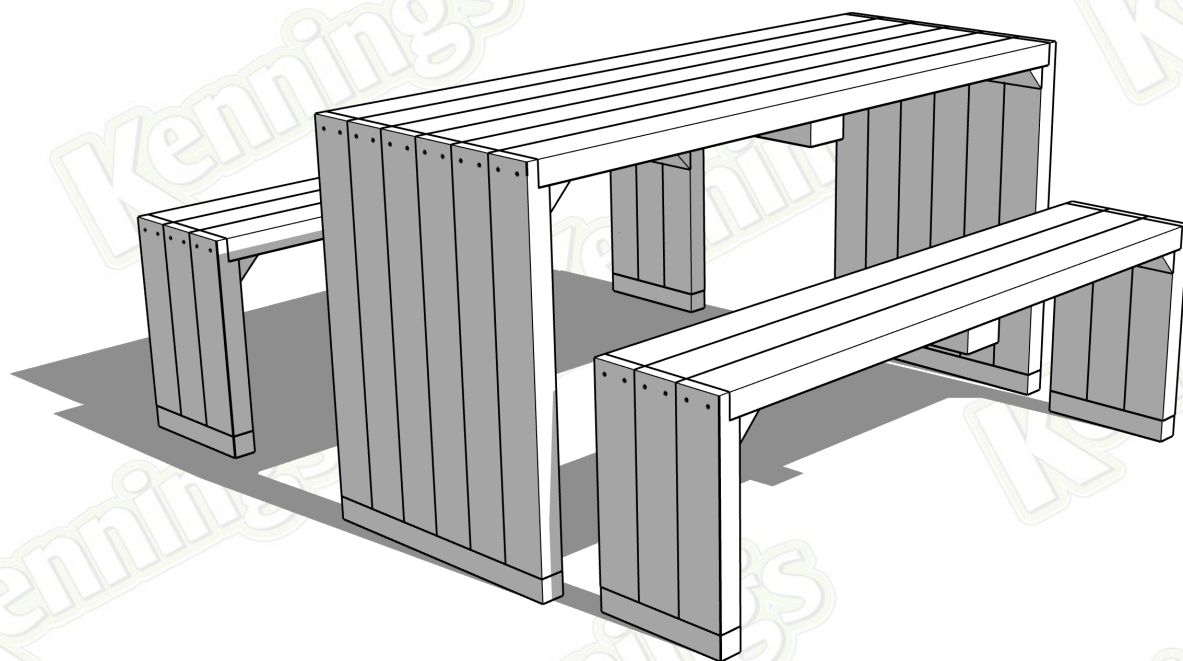

Enjoy your new London Garden Table & Bench Set!

All images are for illustration only. Please see individual item listings for actual item specifications.

Page 6 of 6